



DESIGN AND CONSTRUCTION OF AN ELECTROMAGNETIC DIRECT CURRENT GENERATOR POWERED SINGLE PHASE 60WATTS VOLTAGE SOURCE INVERTER

Chidi C. Uhuegbu and Scholastica C. Ogbodo

Department of Physical and geosciences, Godfrey Okoye University Enugu, Enugu State Nigeria

ABSTRACT: This project: “design and construction of electromagnetic DC generator powered 60watts single phase voltage source inverter” utilizes the internal energy of a rotating magnetic field which induces potential differences across the windings of an electromagnet to enable a continuous feedback process of recharging a 12V battery which supplies a consistent direct current signal to the inverter for conversion into alternating current rating 60watts/230V. The 230V/50Hz is equivalent to the voltage/frequency specifications required for operating electrical gadgets in our homes. The inverter system comprised of the astable multivibrator, the transistor amplifiers, and the high power switching MOSFET and inverter transformer and the output signal of 60watts. So appliances within this range will function effectively when powered by this inverter.

1. Introduction

A magnetic motor utilizes its natural properties of attraction and repulsion of the magnet pole to create an almost perpetual motion which can be harnessed to generate voltage signals of reasonable amount that can comfortably charge a battery that will supply direct current (DC) to the inverter for conversion to alternating current (AC) [1,3,5]. In a bid to reduce the huge cost involved in power distribution and other expensive renewable sources of electricity, this project presents a more effective way of harnessing the energy around the environment of a permanent magnet to achieve constant supply of electricity via the conversion of DC to AC with the help of an inverter [2, 6-10]. An electromagnet is made up of a coil of wire wrapped around a core of ferromagnetic- metallic material such as iron nails or mild steel with a reasonable level of conductivity. When the coil is placed in a magnetic field, electromotive force (EMF) is induced inside of the coil. The DC current produced from the electromagnet is governed by Faradays law of electromagnetic induction. In this process, a conductor is

put in a particular position and magnetic field keeps varying or is stationary and the conductor is moving. In this design, the former is applicable [11-20]. The stationary or varying magnetic field produces an electromotive force (EMF) across the electrical conductor.

The inverter is there to convert the direct current output from the battery to alternating current. The output signal from the magnetic motor is amplified to charge the battery which stores the Direct current signal. The direct current is converted to alternating current by the oscillator of the inverter. Transistor and MOSFET drivers are there to boost the AC signal voltage and current respectively. The inversion process is the opposite of rectification which is the conversion of direct current to alternating current. The pulse width modulation (PWM) helps protect the loads from getting damaged. The power from the inverter should be ripple-free, not containing spikes or noise which could lead to the damage of the equipment [20-31].

2. Theoretical Consideration and Calculation

The DC motor is attached to a permanent rare-earth magnet, also known as ferrite magnets because they



contain elements of iron in their core which establishes a magnetic field. The electromagnet serves as the energizer to the magnetic field already created.

Laws of Electromagnetism

Faraday’s Principle of Electromagnetic Induction can be described in two ways:

✓ A moving conductor cutting the lines of forces (flux) of a constant magnetic field has a voltage induced into it.

✓ A changing magnetic flux inside a loop made from a conductor material will induce a voltage in the loop. .

Mathematically:

| E | = N dΦ / dt

Where | E | is the magnitude of the induced electromotive force (e.m.f)

N is the number of turns

dΦ / dt is the time rate of change of the magnetic flux.

The change in flux between t = t₁ and t = t₂ is given by the integral of the above expression with respect to t.

Therefore, Δ Φ = 1/N ∫ |E| dt

Maxwell’s Equations of Electromagnetism

Maxwell’s equations are a set of four differential equations that bridged the gap between electricity and magnetism.

∇ .D= δρ

∇ .B= 0

∇ ×E = -δB/δt

∇ ×H= J + δD/δt

Lentz Law of Action and Reaction

Lenz law states that the electromagnetic induced currents and forces will cancel the originating cause.

Fleming’s Right-hand Rule

Fleming’s right-hand rule gives the direction of motion in the operation electric generator. This rule defines the path of the current flow in an electromagnetic generator.

F → = qv → × B →

Where F is the magnitude of force in Newton

v is the velocity of the charge q in meter per second

B is the magnetic field in Tesla

Battery

The ratings of the batteries used in this design are 9volt/280mAH and 12volt/7.5AH. The 9volt battery is a low power battery which drives the DC generator, whereas

the 12volts is the storage system for the electromagnetic DC generator output.

Amp-hour Rating

The 9volt battery rating 280mAH (0.28AH) will supply the required power to drive the 6volt electromagnetic DC generator. The power of the DC generator is 0.29watts with 2100revolutions per minute (rpm). To determine the amount of current required to drive the DC motor we apply the power formula:

P = IV

P = 0.29watts

V = 6v

Therefore, I = P/V

= 0.29watts / 6volts

= 0.048A.

Hence, number of hours, H = 0.28AH / 0.048A

= 5.83Hours

The second battery used in this project is a 12volt battery rating 7.2AH; this is the battery that powers the 60watts inverter.

I = P /V;

Where P = 60watt

V= 12volt

I= 60watt / 12volt

=5A

Number of hours H= 7.2AH / 5A

=1.44Hours.

Inverter

An inverter is an electronic device which converts direct current (DC) supply into either a single or three phase alternating current (AC). The 60watt inverter designed in this project is a single phase voltage source inverter because the input is from a DC source from the 12volt battery. It is single phase because it is a low power inverter which produces square waves as output signal, as such can only be used in power supplies. The stages of the 60watts Single Phase Voltage Source Inverter include:

- ❖ Oscillator
- ❖ Transistor amplifiers
- ❖ High power switching MOSFET drivers
- ❖ Step-down transformer
- ❖ Load



3. Experimental Details and Materials

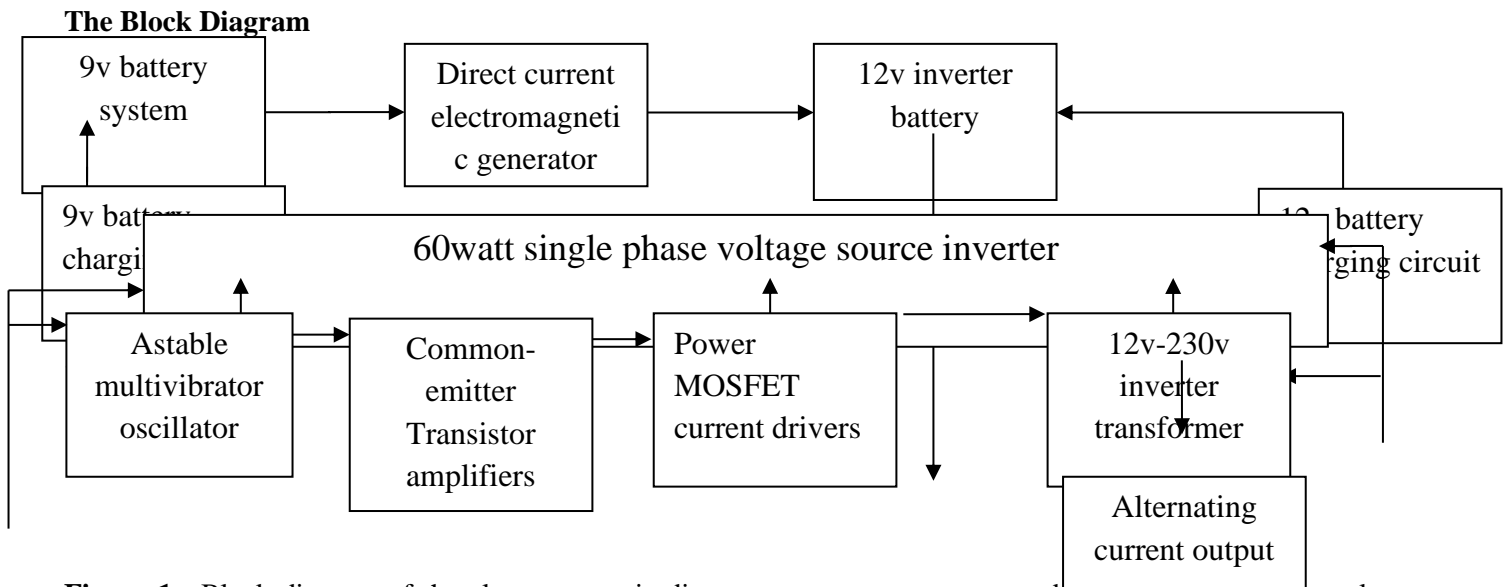

Figure 1. Block diagram of the electromagnetic direct current generator powered single phase 60watts voltage source inverter.

Electromagnetic DC Generator

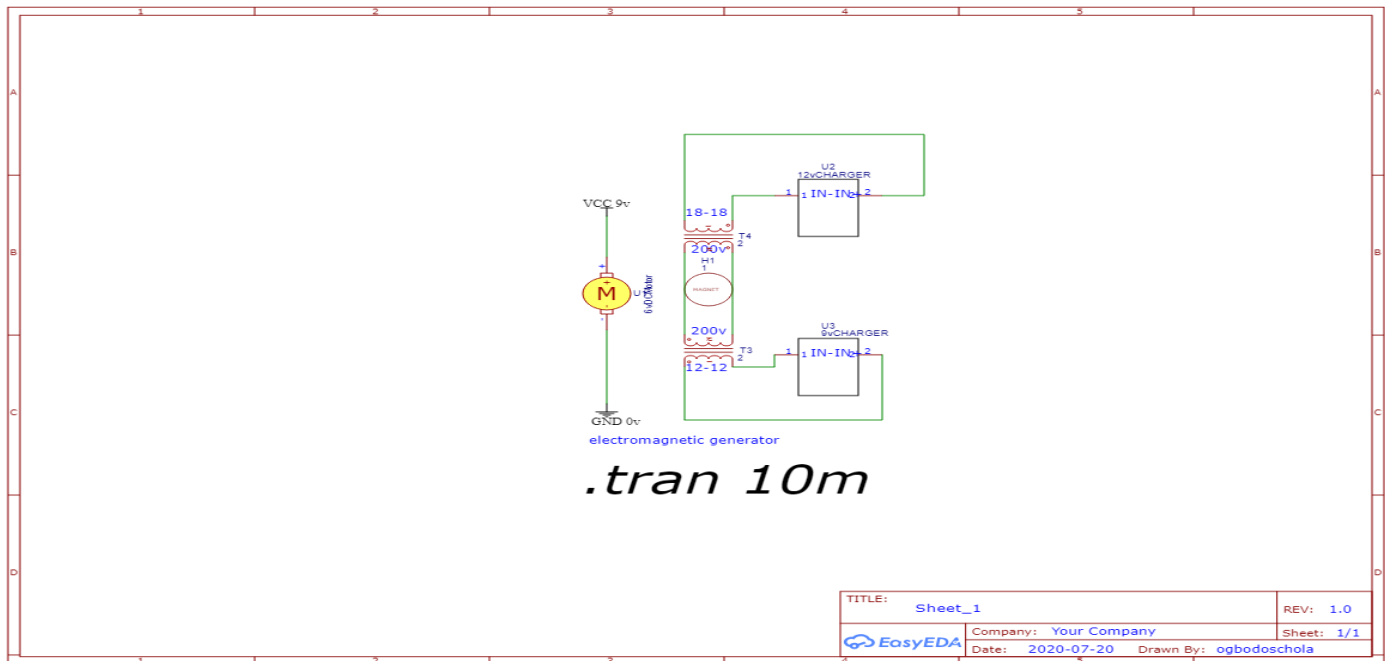

Figure 2. Circuit diagram of the electromagnetic DC generator.

The Design Specifications

DC motor rating = 6volt 2100revolutions per minute (rpm)



The electromagnet is made up of copper coils rating 23 standard wire gauge (SWG) wound round an iron core made of nails. From the standard wire gauges, the 23SWG has a carrying current of 0.58A. The number of turns is 400 for each for the two electromagnets.

The Magnets used are two permanent ferrite ring magnet which has the two unlike poles (north and south). The magnetic field, B of these magnets is a constant of 0.35 Tesla Carter (2017). From Maxwell's equations, $E/B = C$

Where, E = electric field

B = magnetic field

C is the speed of light = 3.0×10^8

$E = B \times C$

$= 0.35T \times 3.0 \times 10^8$

$= 105000000N/C$

$\approx 1.05 \times 10^8 N/C$

The magnetic field strength or magnetic field intensity H is given as

$$B = \mu H$$

Where $\mu = (\mu_0 \times \mu_r)$

μ_0 is the permeability of free space = $4\pi \times 10^{-7} N/A^2$

μ_r is the relative permeability which is dependent on the type of material used as the electromagnetic core. In this project, iron nails are used. The relative permeability of iron $\mu_r = 6.3 \times 10^{-3}$ Henry per meters (H/m).

Therefore $H = B / (\mu_0 \times \mu_r)$

$H = 0.35 \text{ Tesla} / (4\pi \times 10^{-7} N/A^2 \times 6.3 \times 10^{-3} H/m)$

$H = 2.77 \times 10^{-9} A/m.$

The distance separating each electromagnet from the DC generator is 3cm, hence increasing the strength of the magnetic field, B .

Inverter System

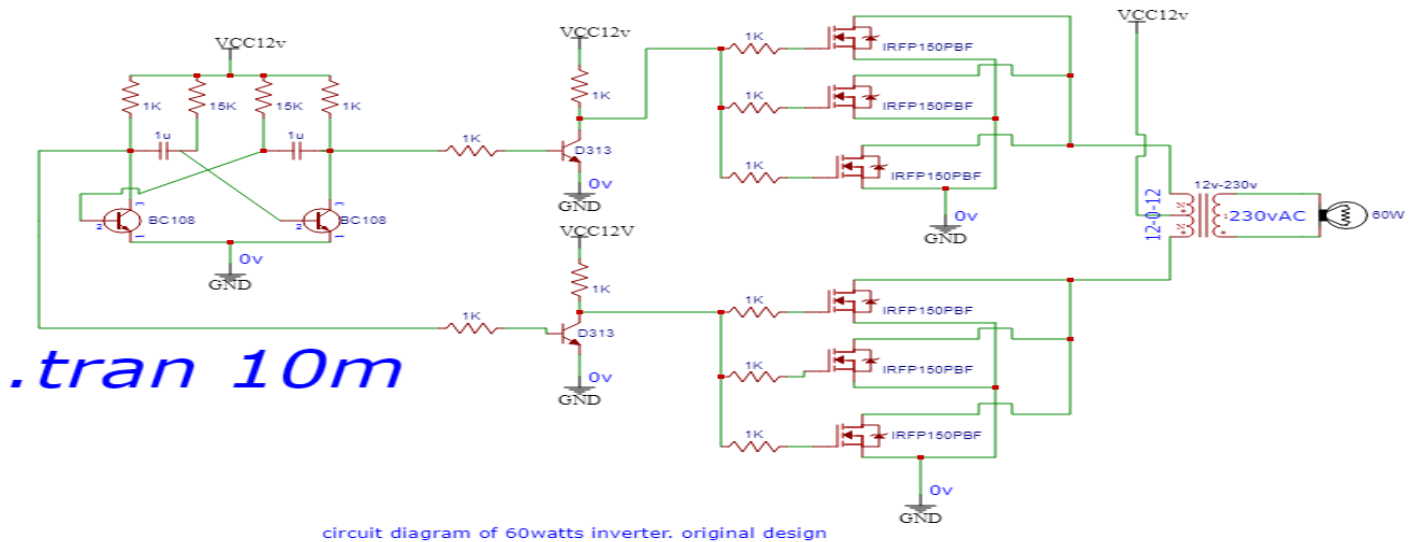

Figure 3. Circuit diagram of the single phase 60watts voltage source inverter

Astable Multivibrator Oscillator

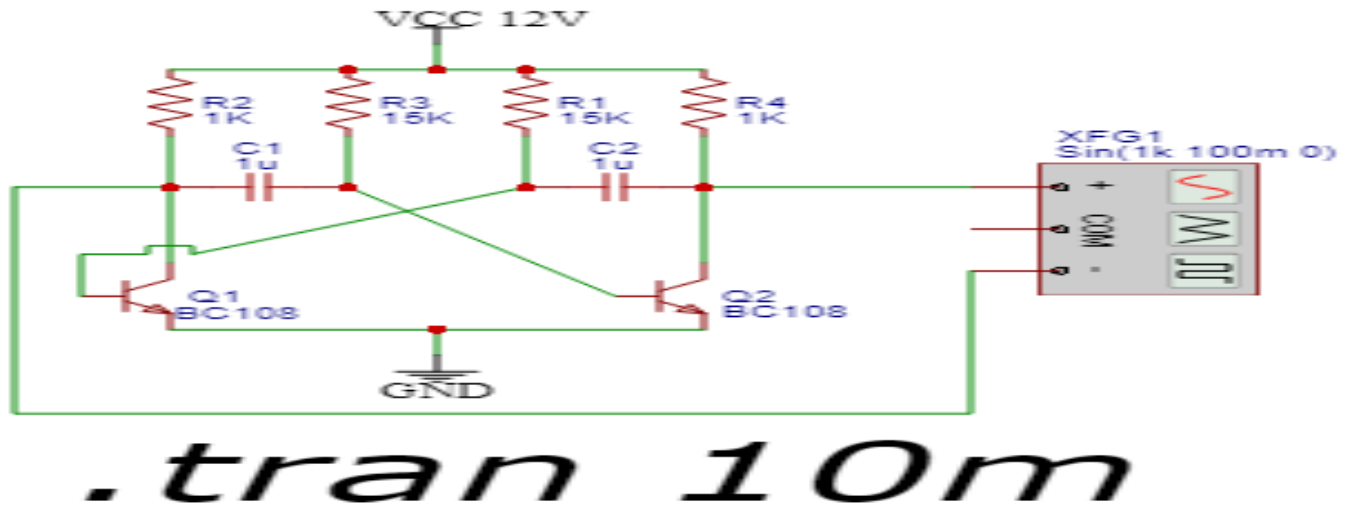

Figure 4. The circuit diagram of the Astable Multivibrator Oscillator.

Design specifications

The time ON and OFF of the vibrators is given as:

$$T_{on} = 0.63R_2C$$

Where, $R_2 = 15K\Omega = 15,000\Omega$

And $C = 1\mu F = 0.000001F$

$$\text{Therefore, } T_{on} = 0.63 (15000 \times 0.000001) = 0.00945\text{seconds}$$

$$T_{off} = 0.63 (R_1 + R_2) C$$

Where $R_1 = 1K\Omega = 1000\Omega$

$$\text{Therefore, } T_{off} = 0.63 (1000+15000) 0.000001 = 0.01008\text{seconds}$$

$$\text{Total time } T = T_{on} + T_{off}$$

$$= 0.00945 + 0.01008$$

$$\text{Therefore, } T = 0.01953$$

Frequency, f of the oscillator = $1 / T$

$$= 1 / 0.01953$$

Therefore the frequency $f = 51.20\text{Hz}$

$\approx 51\text{Hz}$.

The frequency of 51.20Hz is within the range of 50Hz and serves as perfect oscillator circuit for the construction. The values of the resistor and capacitor used greatly determine the frequency of the oscillator, so previous calculations were made before arriving at this values reported in this work. When measured with a frequency meter, the reading raged within 50.9Hz to 52Hz.

The duty cycle of the vibrators can be calculated as follows:

$$D = T_{off} / T_{on} + T_{off} = T_{off} / T$$

$$= 0.01008 / 0.01953$$

$$\text{Therefore, } D = 0.516129$$

≈ 0.5

In percentage, D becomes $0.5 \times 100 = 50\%$

Therefore, the output is HIGH within 50% of the cycle and OFF within the remaining cycle of 50%.

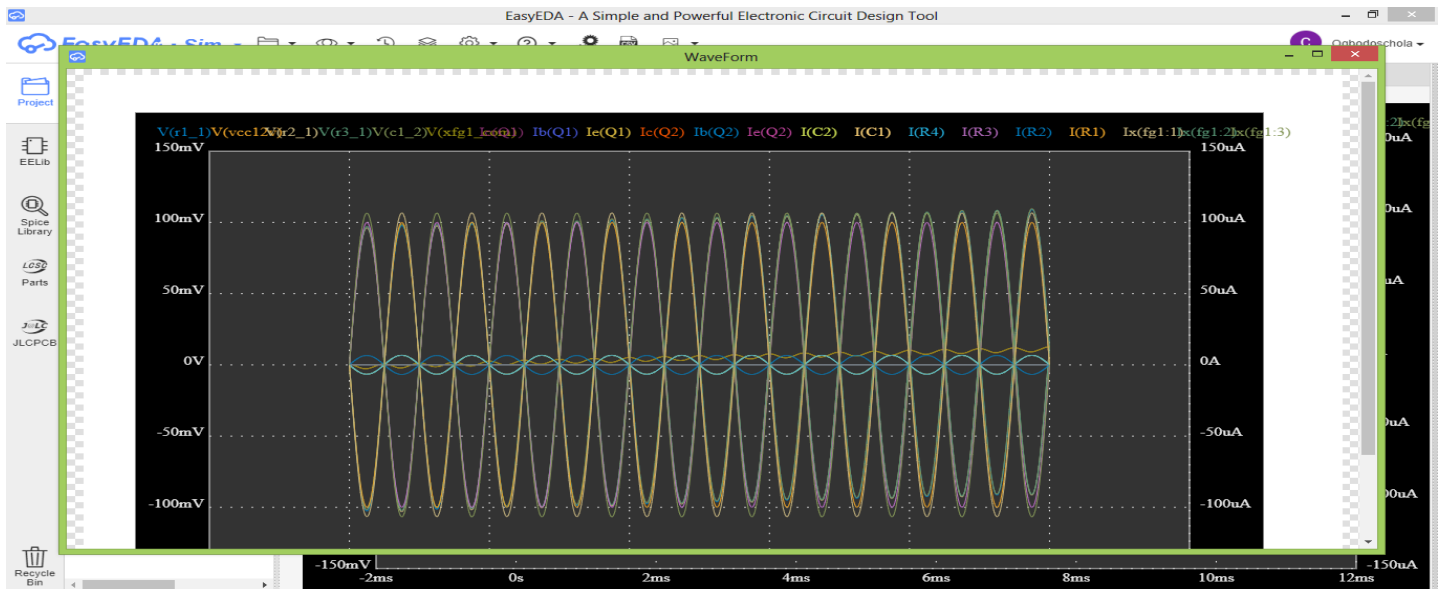
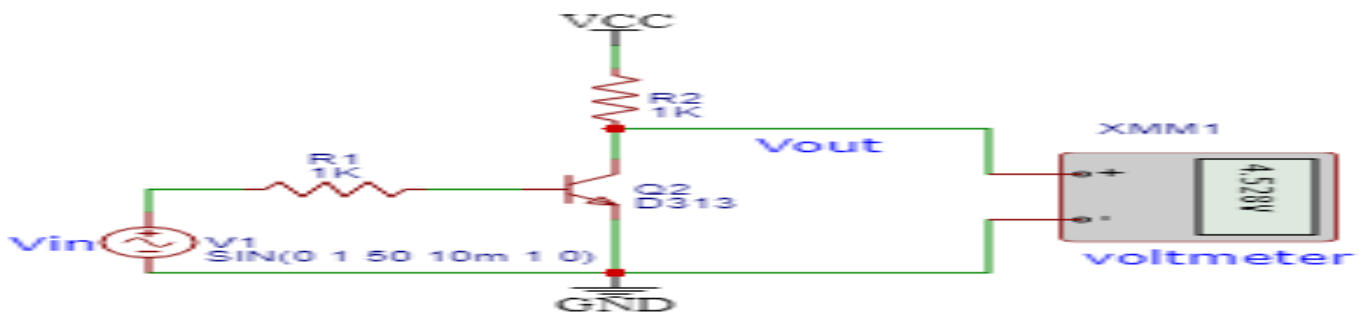

Figure 5. Alternating current signal waveform of the astable multivibrator.
Common-Emitter Transistor Amplifiers



common emitter configuration

.tran 2

Figure 6. Circuit diagram of the common-emitter operation of the transistor amplifiers

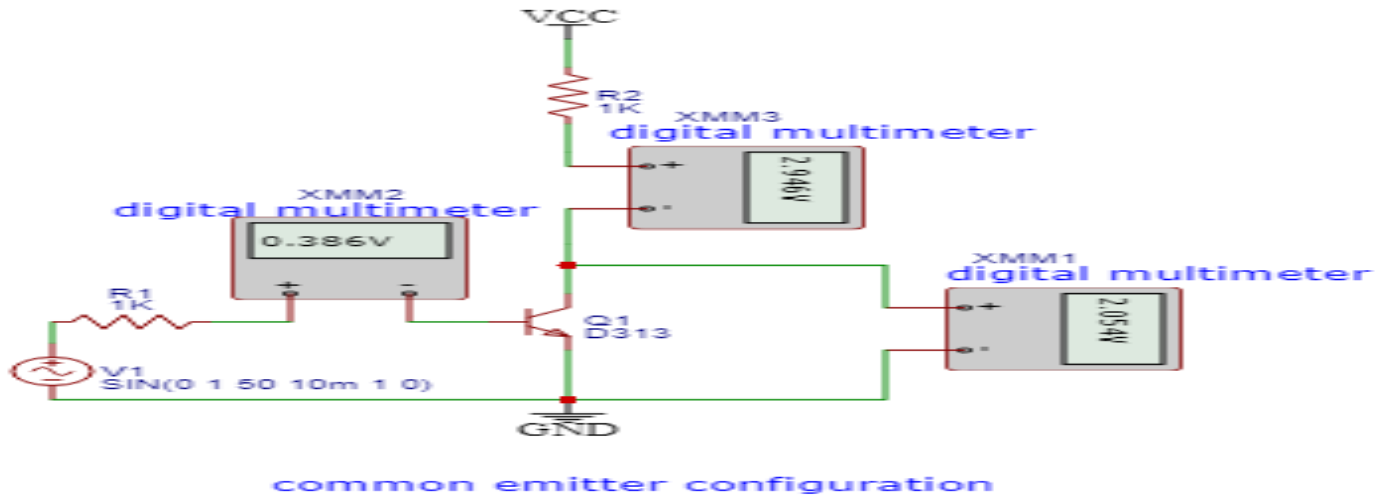

.tran 2

Figure 7. Circuit diagram of the input and output voltages as shown by the readings on the digital voltmeter.

The base current or input current I_b is can be calculated using the formula for potential difference:

$$V_b = I_b \times R_b$$

Where input voltage $V_b = 0.386v$

Input impedance $R_b = 1K\Omega = 1000\Omega$

Therefore, $I_b = V_b / R_b$

$$= 0.386v / 1000\Omega$$

$$= 3.86 \times 10^{-4}amp.$$

The collector current or output current I_c is determined using also the voltage formula

$$V_c = I_c \times R_c$$

And $I_c = V_c / R_c$

Where output voltage V_c reads 2.946v

And the output impedance $R_c = 1K = 1000\Omega$

Therefore, $I_c = 2.946v / 1000\Omega$

$$= 2.946 \times 10^{-3}amp.$$

Now the current gain,

$$\beta = I_c / I_b$$

$$= 2.946 \times 10^{-3}amp / 3.86 \times 10^{-4}amp$$

$$= 7.6321$$

Thus, voltage gain $A_v = \beta R_c / R_b$

Where, $R_c = R_b = 1000\Omega$

Therefore, $A_v = 7.6321 (1000\Omega / 1000\Omega)$

$$= 7.6321voltage$$

The Switching Unit Using MOSFETS

The power MOSFET used is six pieces of N-channel MOSFET with the number IRFP150. The power to be generated depends on the capacity of the MOSFET and with the following ratings.

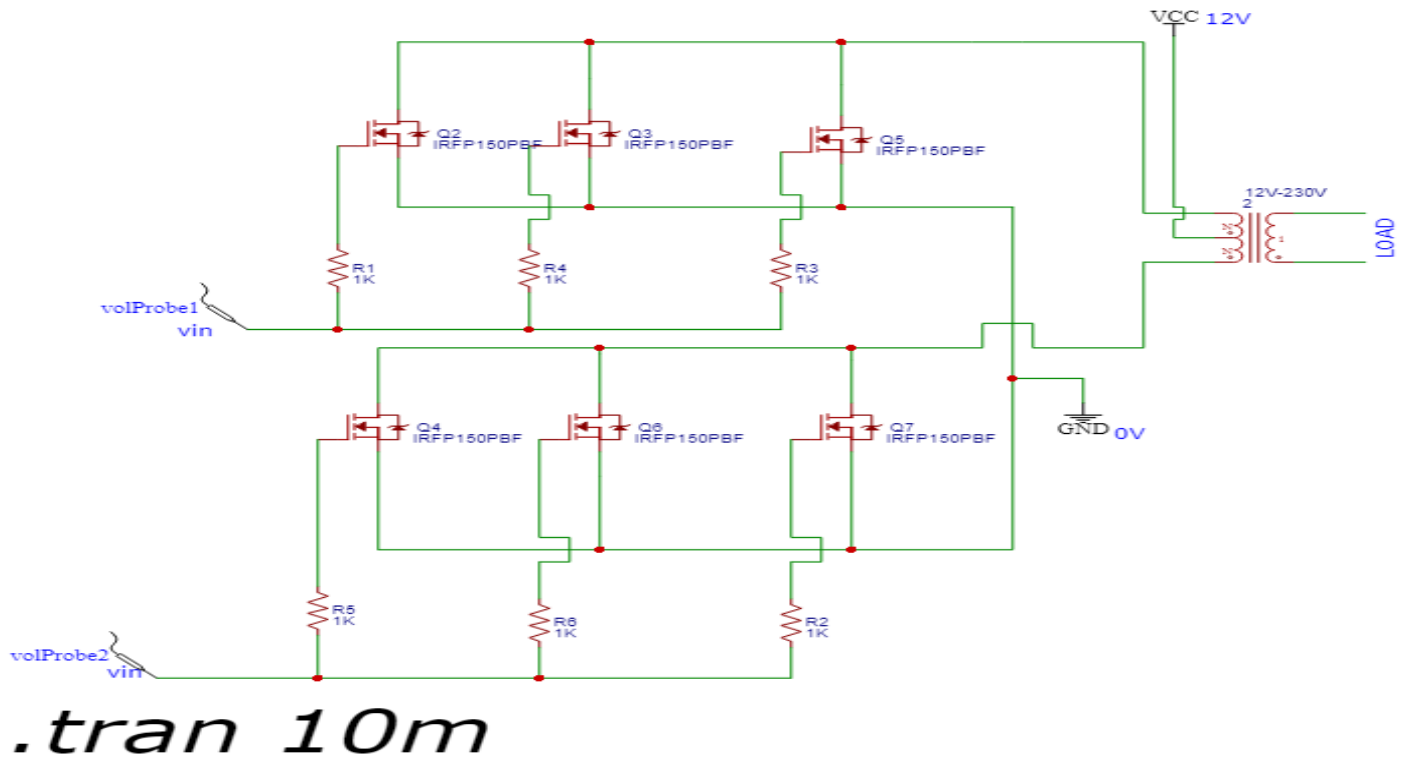

Figure 8. Circuit diagram of high power switching MOSFETs connected in parallel.

The power output for the design is 60VA by using a power factor of $1 \times P \text{ (VA)} = 1 \times 60 = 60 \text{ watts}$

$I = P/V = 60 \text{ watts} / 12 \text{ volts}$ (using the 12volt battery)

Therefore, $I = 5 \text{ A}$

This implies the power MOSFET must have a current handling capacity in excess of 5A.

The maximum AC power for the switching circuit is given as:

$$P_{ac} = V_{cc} \times I_{max} / 2 = 12 \times 5 / 2 = 30 \text{ watts}$$

The power dissipation of the circuit is given by

$$P_{dis} = 2P_{ac} / 2\pi$$

$$= 2 \times 30 / 2 \times 3.142$$

$$= 9.549 \text{ watts}$$

$\approx 9.55 \text{ watts}$.

P_{max} of the MOSFET = $P_{dis} / \text{number of MOSFET per unit}$

$$= 9.55 \text{ watts} / 3$$

$$= 3.183 \text{ watts}$$

From the calculation, the power that will be given out by one MOSFET is 3.183watts.

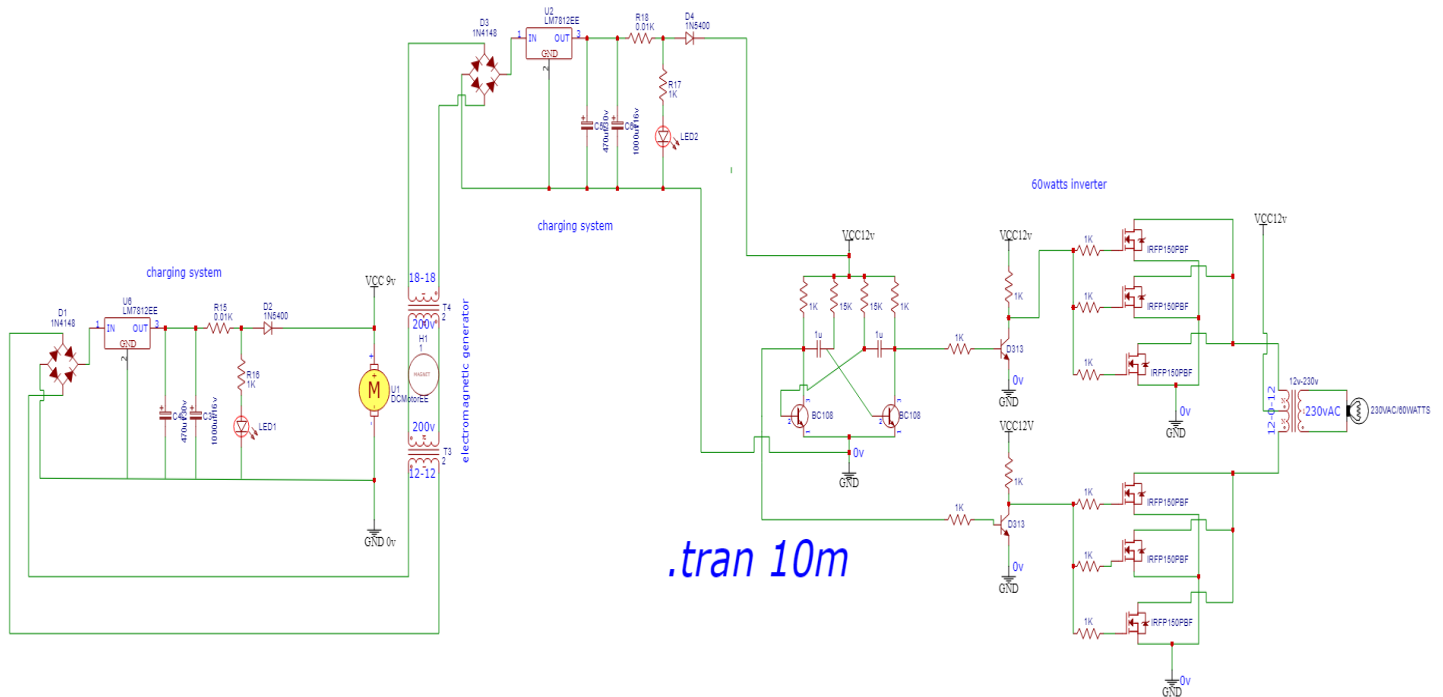
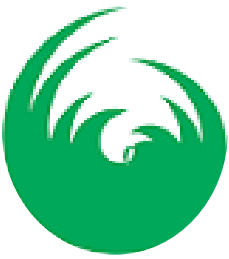

Figure 9. Circuit diagram of electromagnetic DC generator powered single phase voltage source 60watts inverter.

4.

Results and Discussion

After all the stages of this design have been coupled, the output of the system is tested by connecting the voltmeter setting of the digital millimeter to the output terminal of the inverter transformer to test the output voltage and it read 230volts. The frequency of 50Hz was equally proven using a frequency meter. The DC generator and the electromagnets are constructed and mounted on a wooden surface of appropriate dimension and the ferrite permanent magnets lie distance of 4cm along each electromagnet. This little distance is to ensure the attractive force of the magnets is intensified to increase the magnetic field. Figures 4.4a and 4.4b presents the images of the construction process assembling of the electromagnetic direct current generator section of the system.

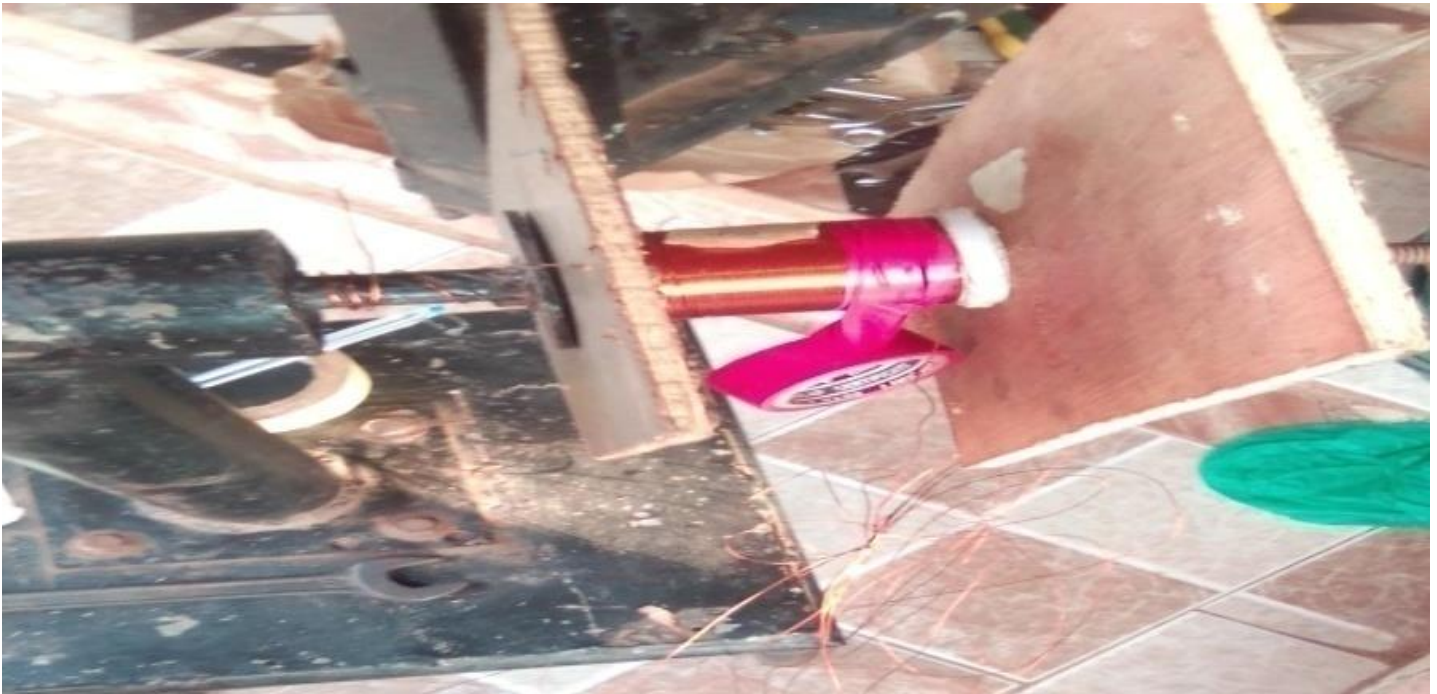

Figure 10. The coiling process of the electromagnetic generator.

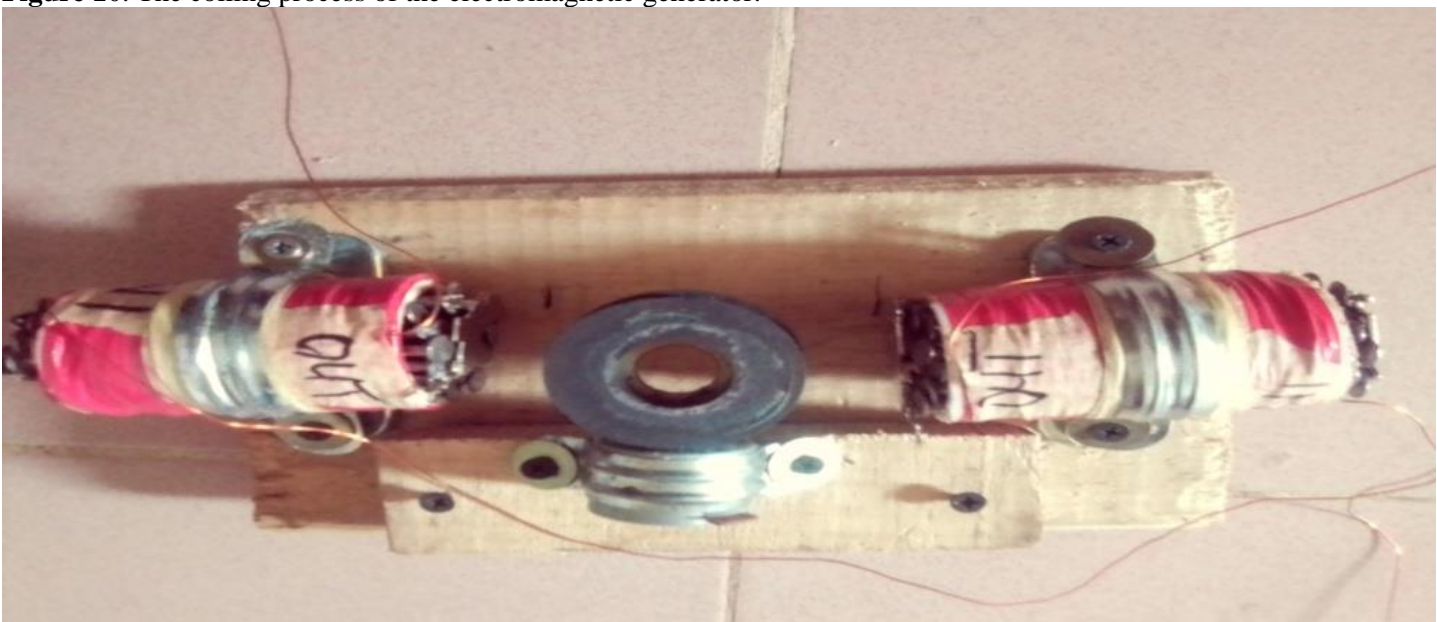

Figure 11. Assembling of the electromagnetic DC generator system.

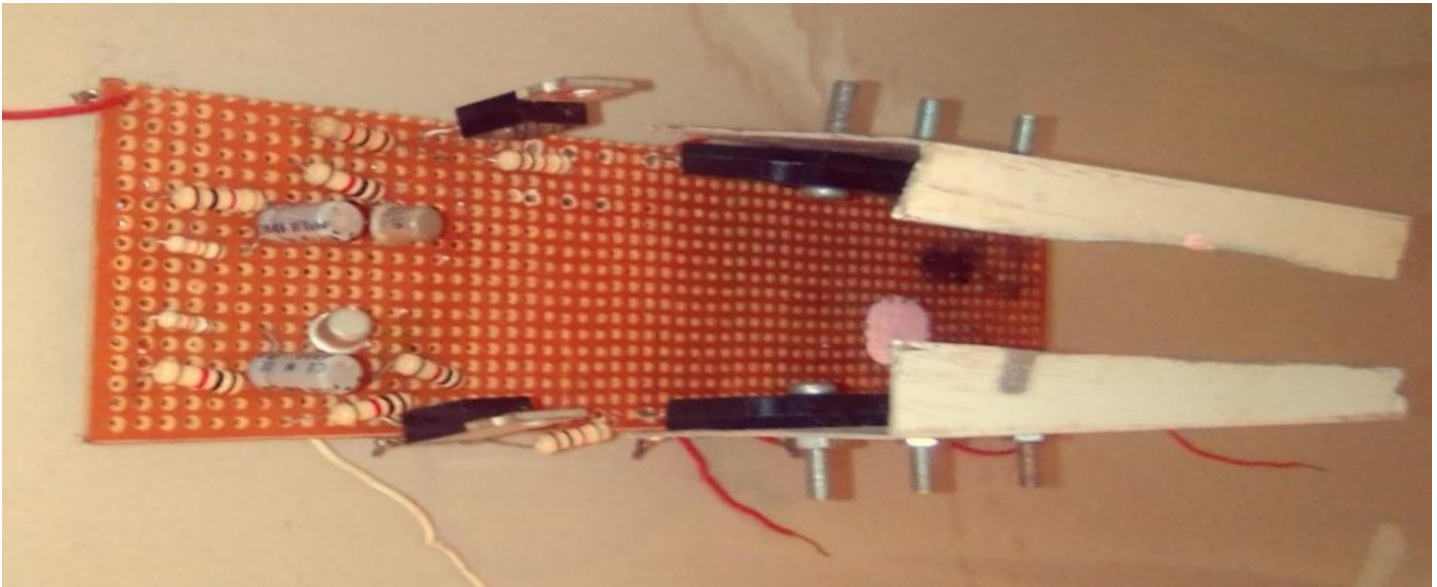

Figure 12. Astable multivibrator and power switching MOSFETS

The Inverter Transformer

The process of construction of the transformer involves the coiling, insulating of the terminal stacking of flat iron steel and lamination of the surface with varnish. winding was

done using 15SWG having a voltage of 12V and output current of 5A. While that of the secondary is 23SWG and it produces an output voltage of 230V and 0.5A current..

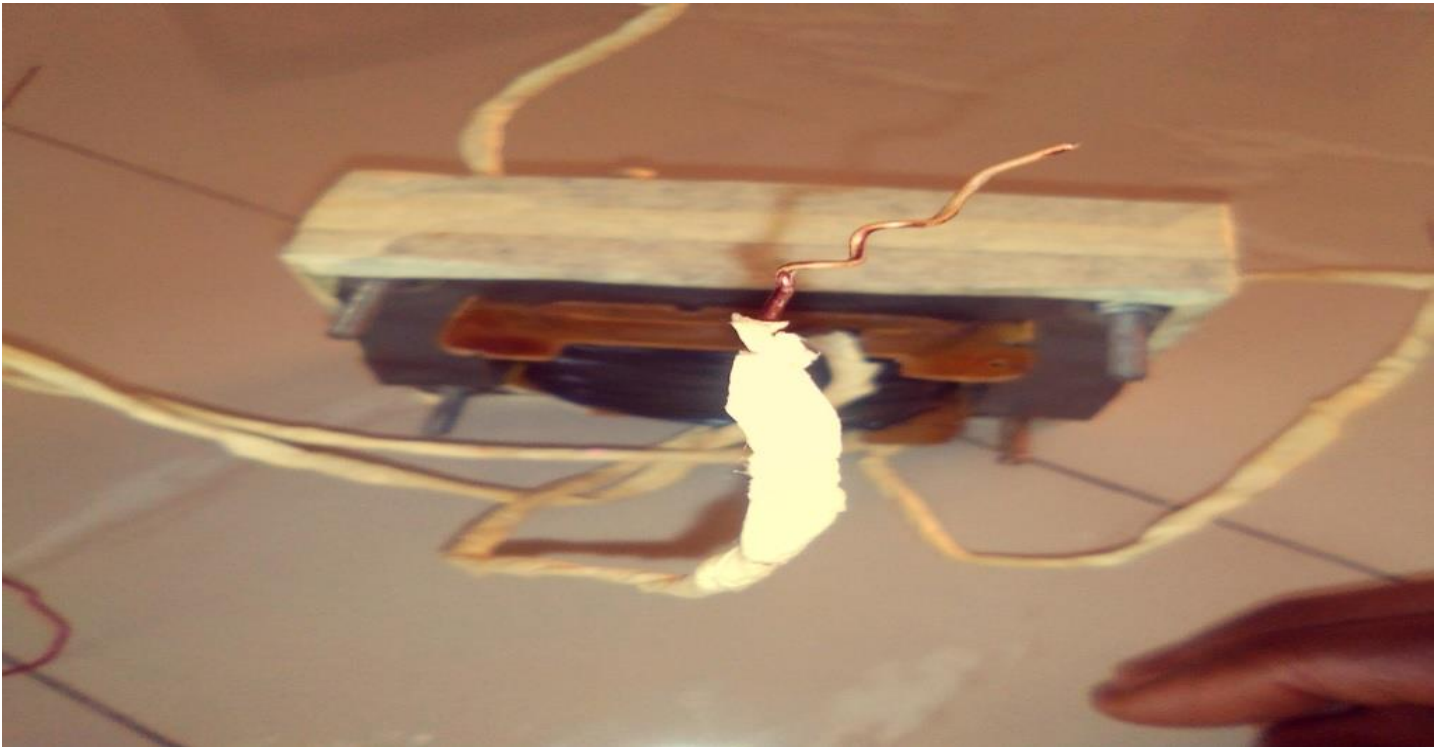

Figure 13. Construction of 12V-0-12V transformer which gives out 230V at the secondary.

Assembling

After all the stages of this design have been coupled, the output of the system is tested by connecting the voltmeter setting of the digital millimeter to the output terminal of the inverter transformer to test the output voltage and it

read 230volts. The frequency of 50Hz was equally proven using a frequency meter. An LED is connected to the output terminal of the inverter which lit to a desired brightness.

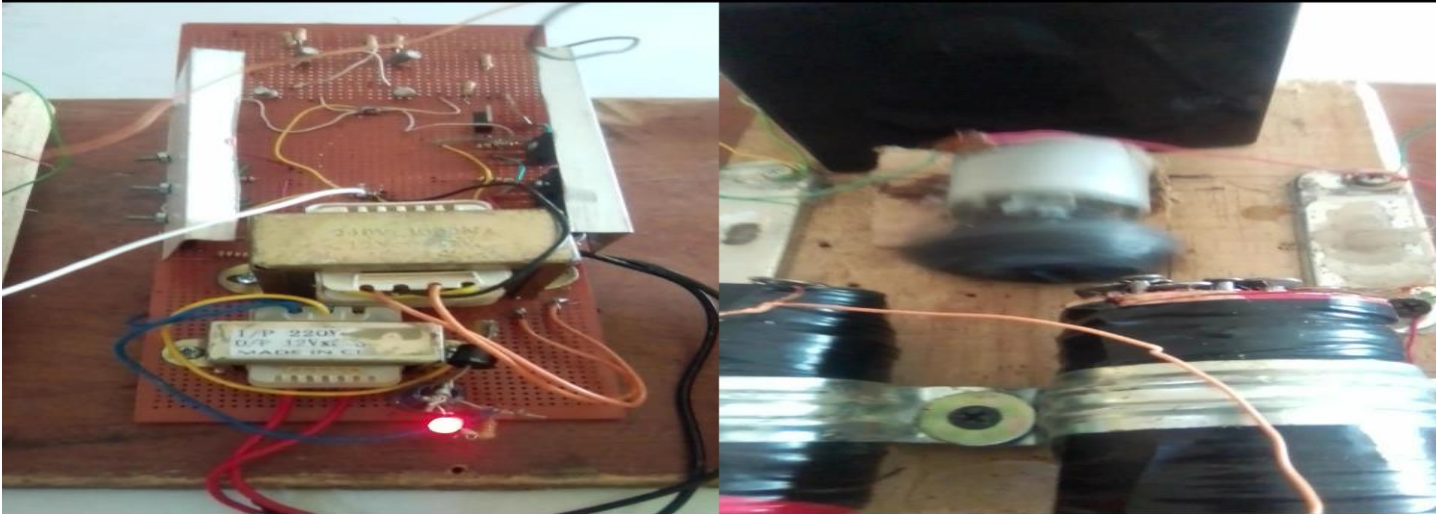

Figure 14. Testing of the electromagnetic DC generator powered inverter system

Conclusion

We have demonstrated the possibility of generating electricity from the internal energy of a magnet when placed in an electromagnetic field. The process predicts that high current will be produced when a high capacity direct current motor is used and when a stronger magnetic field is created by the use of Neodymium magnet of high magnetic strength.

References

Adeyanju, A. Y. (2003). Design and Construction of a 750Watts Inverter. Unpublished B.Tech Thesis, LAUTECH, Ogbomosho, Nigeria.

Akpan, V. Ewetomo, T. (2010). Development and Construction of a Low Cost Automatic 2KVA Inverter System. *Global Journal of Pure and Applied Sciences*. (16):141-148.

Alumona, T.L. (2016). Design and Construction of an RF Remote Control 5KVA Inverter System. *International Journal of Computer Science and Mobile Computing*. (5): 570-583.

Amikan, A. (1996). Introduction to the Theory of Ferromagnetism. United States, New York: Oxford University Press.

Andrew, A.L (1998). Applied Physics for Electronic Technology. London: Arnold Holder Headline Publishers.

Culity, B.D. and Graham, C.D. (2009). Introduction to Magnetic Materials. U.S.A: John Wiley and Sons, Inc Publication.

Ehikhamenla, M. Okeke, R.O. (2017). Design and Development of 2.5KVA Inverter Adopting a Microcontroller Based Frequency Meter. (3)1-14.

Franco, S. (1995). Design of Operational Amplifier and Analogue Integrated Circuit. Singapore: McGraw Hill Books Company, pp43-441.

Griffiths, D.J. College R. (1999). Introduction to Electrodynamics. Upper Saddle River, New Jersey: Prentice Hall Inc.

Gupta, J. B. (2012). Electrical Machines (14 Ed.). New Delhi, India: Tata McGraw-Hill Publishing Company
Ltd.http://www.datasheetcatalog.com/datasheets_pdf/A/D/C/0/ADC0804.shtml, 2015
<http://www.maxim.com> IC SG 3524 Pulse Width Modulation.



- HUGES, E. (1993). *Electrical Technology*. Moscow, Russia: Planet publishers. [http://en.wikipedia.org/wiki/inverter \(electrical\)](http://en.wikipedia.org/wiki/inverter_(electrical)), 2015.
- Hughes, E. (1998). *Electrical Technology (6th Ed.)*. London: Longman Scientific Technological Book Series.
- James, A. (2005). *Introduction to Electric Circuit (5th Ed.)*. United States: New York Press.
- John, C. Peter, S and James, W. (1995). *Electromechanical Systems*. London: The Engineering Council.
- Klempner, G. and Kerzenbaum, I. (2004). *Operation and Maintenance of Large Turbo Generators*. John Wiley and Sons Inc.
- Knight, R.D. (2004). *Physics for Scientists and Engineers: A Strategic Approach*. San Francisco.
- Lindemann, P.A. (2000). *The Free Energy Secrets of Cold Energy*. Metaline Falls, WA: Clear Tech. Inc.
- Mani, A.K. (1998). *Electronic Projects for Beginners*. New Delhi: An Indian Publication.
- Michio, K. (2008). *Physics of the Impossible*. U.S.A: Doubleday.
- Muhammed, R. (2011). *Power Electronics Handbook*. India: Elsevier Inc.
- Nelson, J. C. (1986). *Basic Operation Amplifier*. London: Butter Worth and Co. Limited.
- Ronald, J. T. and Neal, S. W. (1998). *Digital System Principle and Applications, 7th Edition*. London: Prentice-Hill International Inc.
- Sandeep, T, Swapnil, H. Anad, S. Shubham, R. (2018). *Self-Generator Free Energy Flywheel*. *International Research Journal of Engineering and Technology* (5):1062-1064.
- Say, M. G. (1978). *Alternating Current Machines*. Pitman Publishing.
- Setrap. M. P. (2008). *Fundamentals of Inverter Designs*. USA: Junavo & Kelino Co.
- Theraja, B.L. Theraja, A.K. (2005). *A Textbook of Electrical Technology (1)*. New Delhi: S.Chads & Companies LTD.
- Vinoth, M.A. (2019). *Experimental Designs and Optimization of Free Energy Generator by Using Neodymium Magnets*. *International Journal of Advanced Research in Management, Architecture, Technology and Engineering*. (3):97-100.
- Wildi, T. *Electrical Machines, Drives and Power Systems*. Prentice Hall.
- Zorbas, D. (1989). *Electric Machines-Principles, Applications, and Control Schematics*. West.